

SCHNITT A-A
MABSTAB 1 : 15

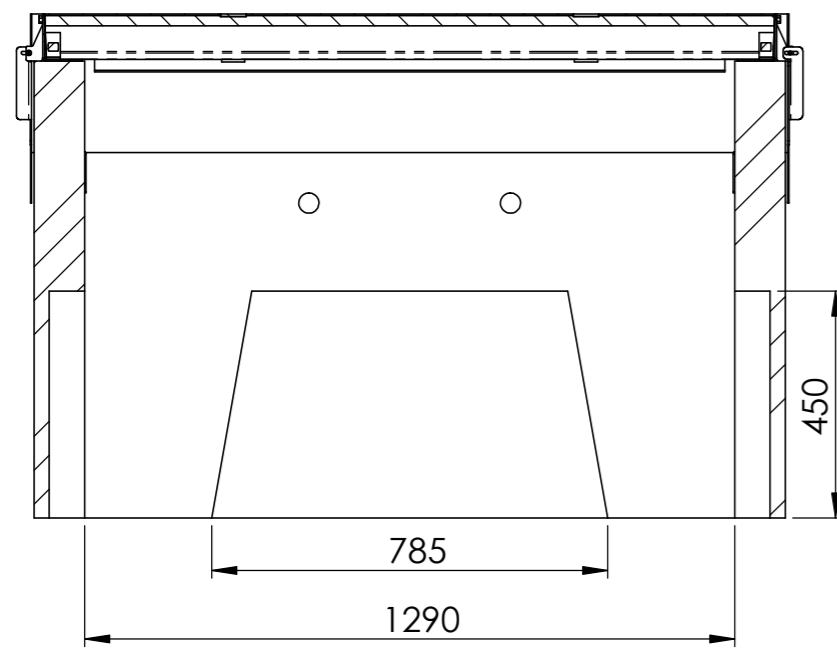
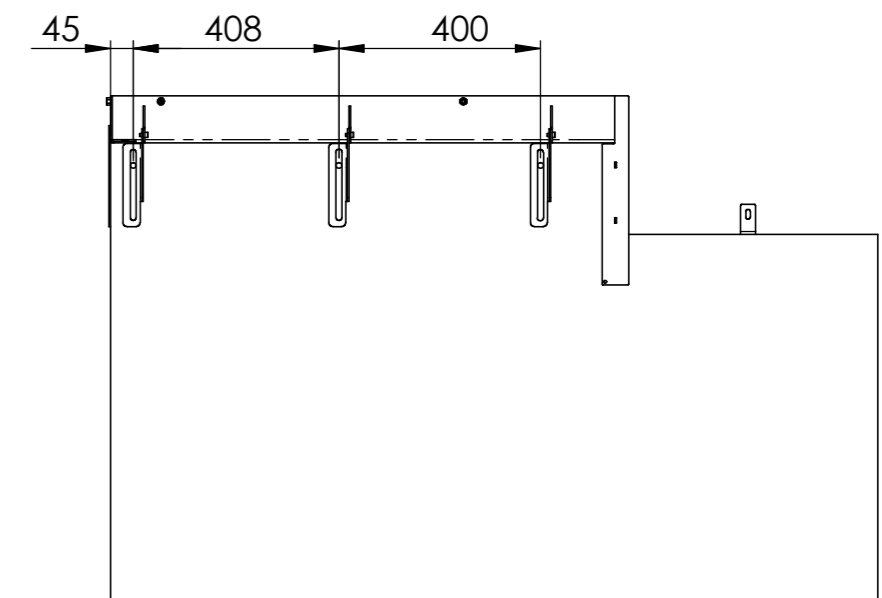

SCHNITT B-B
MABSTAB 1 : 15

2x ECO.1005.D.B125
Optional A15 Variante mit Metalldeckel M1.1005.D.ECO.A15

1x Rahmen FB13L

1x Fundament FB13L

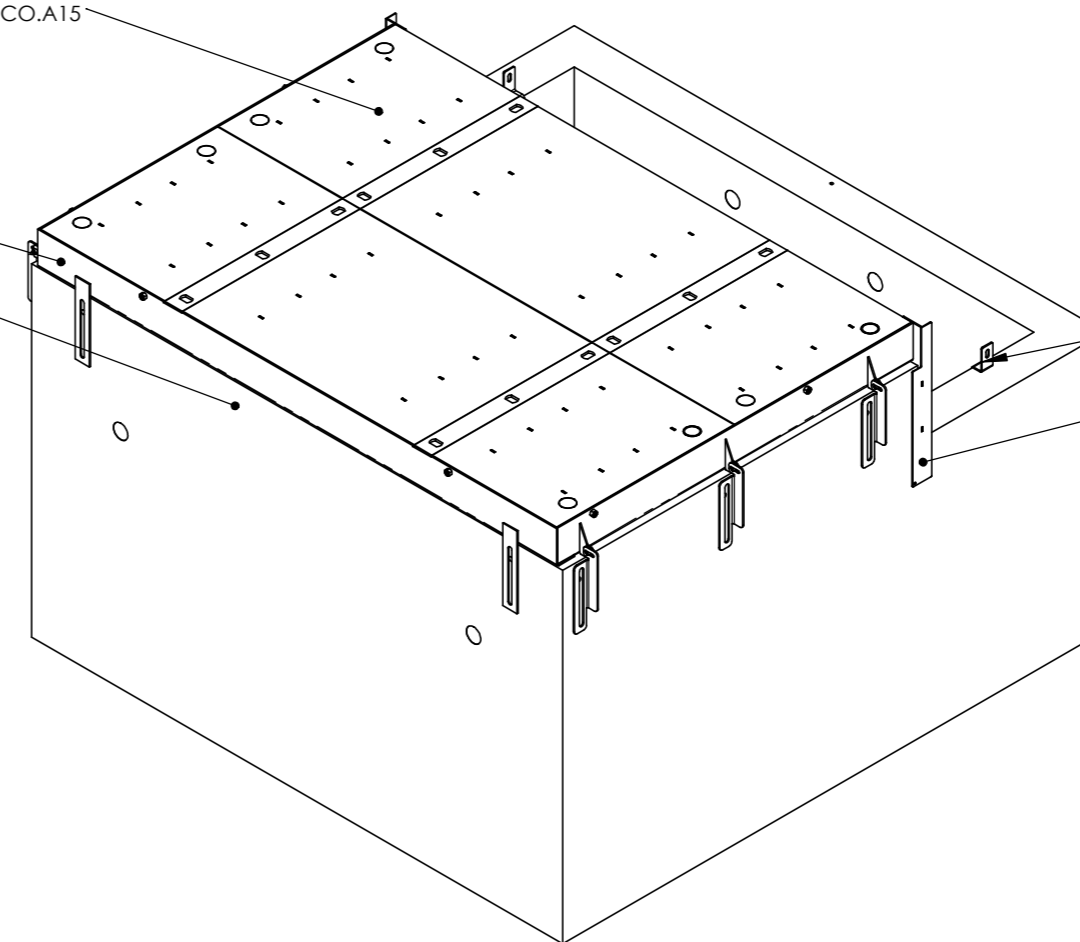

2x Kabinenhalterung

2x Schmutzschleuse

Allgemeintoleranzen ISO 2768-m		Material:		Gewicht: 950 Kg	
FB13L + Florida 13 Ohne Kabine B125/A15			Massstab 1:5	Gezeichnet	MH 14.12.2020
				Geprüft	MH 14.12.2020
			Format A2	Zeichnungsnr. 020-560	Datum Name

BETOX
Innovative Schachtsysteme